



Comparison of Anolyte to Chlorine

Chlorine is currently the most widely used oxidizing biocide. It is a powerful oxidant and is used in bleaching and disinfectants.

The use of chlorine as a micro-biocide and water disinfectant is declining because of safety, environmental, and community impact considerations. According to the MSDS for chlorine, this chemical is highly toxic, corrosive, and may be fatal if inhaled. It is considered to be a marine pollutant, and in the upper atmosphere, chlorine atoms have been implicated in the destruction of the ozone layer. An environmentally sound alternative to chlorine and other oxidizing biocides is needed.

Various alternatives to chlorine use have been explored, including bleach, bleach with bromide, bromochlorodimethyl hydantoin (BBCDMH), non-oxidizing biocides, ozone, ultraviolet, chlorine dioxide, sodium chlorite, chloramine (chlorine & ammonia), copper-silver ionization, and thermal disinfection. Alternative Systems include chlorinators, electrically generated ozonators, and copper/silver cathodes which use electrical activity to cause the release of silver and copper ions into drinking water. Each chemical and System offers some unique advantages, but each has distinct disadvantages.

The Hypochlorous Acid (HOCL) of Anolyte is found to have the advantages of other biocidal alternates without their disadvantages. Categories of objective analysis include efficacy, safety, taste and odors, impact on equipment and systems, effect on scale, biofilm, residual effects, ease of use, maintenance, and cost.

Anolyte is a mixed-oxidant solution. Although it is measured and dosed as free available chlorine, it exhibits behavioral traits associated with a more active chlor-oxygen chemistry than traditional chlorine. In contrast to other chlorine technologies, mixed oxidants such as Anolyte offer superior disinfection efficacy, elimination of biofilm, more durable chlorine residual levels, and reduced formation of disinfection by-products. Mixed oxidants readily oxidize ammonia, sulfides, iron, and manganese, and can cause a micro flocculation effect (reduction in turbidity) in pretreatment. In addition, mixed oxidants offer improved taste and odor. Anolyte even at residual levels over 12 ppm in treated water, leaves minimal to no odor or chlorine taste.

Production of Anolyte is like the process of fabricating standard sodium hypochlorite (NaOCl), with a few significant differences. Sodium hypochlorite is synthesized out of concentrated salt brine which forms formations of stagnant toxic zones from within the conventional electrolysis procedure and combines caustic soda (lye) to stabilize the volatile unstable chlorine. The manufacture of Anolyte eliminates the use of caustic soda by instead using high rejection membrane technology in special polymer diaphragmatic round cells, and diluted brine solutions to produce a naturally activated aqueous solution with pure HOCl thus allowing highly effective evacuation of products of electrochemical and chemical reactions from the separate chambers. The benefits of HOCl become immediately evident when used as a biocide. Elimination of lye makes disinfection possible without the high pH elements associated with sodium hypochlorite. Synthesis of electrochemically activated solutions is only possible when unipolar electrochemical exposure is combined with treatment of as many as possible micro volumes of liquid in a high voltage electric field of a double electric layer near the electrode's surface. Anolyte exists at a neutral pH (7-8), thereby delivering high efficacy in short contact times without the use of caustics. The human body pH level is approximately 7.3; therefore, Anolyte falls within the range where it is safe for the human body.

Independent research has confirmed that the effectiveness of Anolyte in reducing total microbial counts is

superior to that of sodium hypochlorite. The biocidal activity of HOCl generated by the current ECA technology is 300 times more active than the sodium hypochlorite generated by earlier systems. Sodium hypochlorite or gaseous chlorine at the same concentration as that found in Anolyte leads to slower microbial kill and more corrosion when tested per ASTM guidelines.

Activated solutions such as Anolyte have been conclusively shown to exceed chemically-derived equivalents both in low dosage effectiveness as well as physicochemical purity. This heightened biocidal capacity relative to traditional chemical solutions permits the use of Anolyte at lower dose rates, decreasing the risk of adverse environmental impact.

Full Spectrum Total Turn-Key Services

OmniLyte Enviro Inc provides Full Spectrum, Total Turn-Key Services in the build-up of OmniLyte commercial water electrolyzers into composite operating systems with Warranty and Follow-On Technical Support Services.

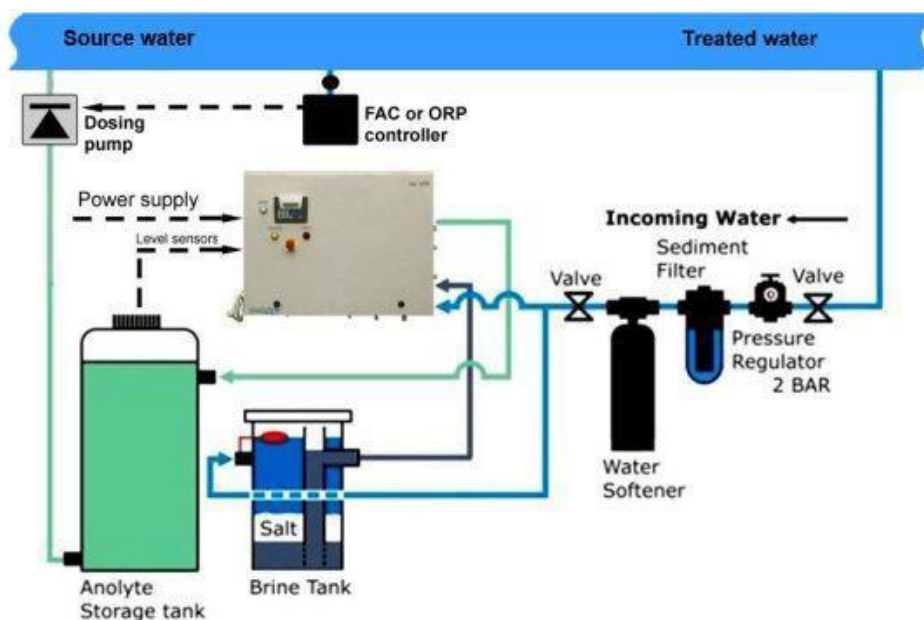

OmniLyte Enviro Inc

P.O. Box 328, Wawanessa, MB R0K 2G0, Canada

Tel: 204 824 4446 Fax: 888 433 8415

E-Mail: info@omnilyte.com Internet: www.omnilyte.com